

ideal



+
**DOMESTIC BOILER
RANGE & ACCESSORIES**
FROM IDEAL BOILERS.



WWW.IDEALBOILERS.COM

+ WELCOME TO FIRST CLASS.



THE QUEEN'S AWARDS
FOR ENTERPRISE



AS TECHNOLOGIES CONTINUE TO DEVELOP, WE UNDERSTAND THAT YOU WANT A LONG TERM PARTNER WHO HAS THE SKILLS AND EXPERTISE TO DELIVER YOU A WIDE RANGE OF PRACTICAL AND RELIABLE HOT WATER AND HEATING SOLUTIONS, THAT ARE SIMPLE TO INSTALL AND EASY TO SERVICE.

Here at Ideal Boilers, we can provide you with just that. When you choose to work with Ideal you can be confident in the knowledge that our rigorous research and development procedures ensure that our products are not only reliable, but have also been designed and built with you in mind.

CONTENTS.

GET MORE WITH IDEAL

04-05 SERVICE & SUPPORT

THE LOGIC+ RANGE

06-15 **LOGIC+** COMBI
LOGIC+ SYSTEM
LOGIC+ HEAT

THE VOGUE GEN2 RANGE

16-21 **VOGUE** GEN2 COMBI
VOGUE GEN2 SYSTEM

CONTROLS & ACCESSORIES

22-23 THERMOSTATS, TIMERS
& IDEAL SYSTEM FILTER
24-25 LPG CONVERSION KITS

HIGH EFFICIENCY CYLINDERS

26-29 IDEAL UNVENTED CYLINDER

FLUE SITING & FLUE KITS

30 FLUE SITING
31 FLUE KITS

+

GET MORE WITH IDEAL.

SERVICE REMINDERS

Our Service Reminders are simple to use and mean you could generate up to 10 years additional service revenue from the Ideal boilers you fit.

Once you're registered for our Service Reminder scheme, for every Ideal boiler you install, we'll make sure we contact you and your customer when a boiler's service is due.

- We'll send your customer your name and contact number for them to give you a call and book a service
- We'll then send you a text to let you know we've contacted your customer so that you can follow up with them

AFTERSALES SUPPORT

With a range of tools to help you grow your business, Ideal is on hand to ensure you have the support you need.

Our dedicated Customer Service department is available 364 days a year.

Monday to Friday	08:00 – 18:00
Saturday and Bank Holidays (excluding Christmas Day)	08:00 – 16:00
Sundays	08:00 – 12:00

- Installer Helpline **01482 498663**
- Homeowner Helpline **01482 498660**

You can also text us for a technical help call back. Text 60777 and start your message with IDEAL.

We also have a team of expert engineers, fully trained to exacting standards and Gas Safe registered, on hand to provide one-to-one advice on the road, over the phone or online ensuring you're fully supported, wherever and whenever you need.

PARTS REQUESTS

Ideal's extensive quality testing procedures ensure that all of our products are manufactured to the highest quality standards.

In the unlikely event that a spare part is required, you can rest assured that most parts are readily available to order via your local spares outlet for up to 10 years after appliance production has ceased.

Ideal spare parts can be obtained from any of Ideal's nationwide network of approved stockists.

For more information about Ideal spare parts and for a list of stockists, please visit our website or call our parts department on:

01482 498665
www.idealparts.com



RELIABILITY

Not only do Ideal boilers go through 200 quality checks before they leave our factory, our Customer Service department is open 364 days a year 7 days a week. We offer a range of warranties up to ten years for total piece of mind.



EASY INSTALLATION

All Ideal boilers are built with the installer in mind with standardised controls across Ideal range. Through extensive field trials and installer clinics we are confident that our range of boilers are easy to install with plenty of room inside to manoeuvre.



BUSINESS SUPPORT TAILORED TO YOU

Installer Connect is the installer loyalty scheme from Ideal Boilers. The scheme rewards you for the Ideal boilers you install, as well as offering a number of business support services.

- Up to £55 of Installer Connect points
- Free Gas Safe warranty notifications
- Easy warranty registrations

To find out more or to become a member, visit:

www.installerconnect.com

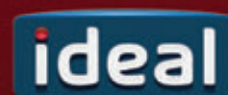

+ LOGIC+

THE LOGIC+ IS THE FLAGSHIP RANGE OF HIGH EFFICIENCY BOILERS FROM IDEAL. COMPACT IN SIZE AND FULLY MODULATING DOWN TO AS LOW AS 4.8kW, THE LOGIC+ PROVIDES EXCELLENT ENERGY SAVINGS MAKING IT THE PERFECT CHOICE FOR NEW OR REPLACEMENT INSTALLATIONS.

Siting a Logic+ boiler is quick and simple thanks to a telescopic flue, fast fix flue turret connections and zero compartment ventilation, which allows neat installation into a standard kitchen cupboard (always check measurements before installation).

Thanks to unrivalled levels of reliability, the Logic+ range of boilers comes with a 7 year warranty* and is supported by the Queen's Award for Enterprise 2013, Good Housekeeping Reader Recommendation and Product of the Year award 2014.

The Logic+ range has been designed to ensure a quick and hassle-free installation. Benefiting from concealed connections and comprehensive controls, all models also feature a translucent condensate siphon to allow any debris to be spotted quickly and easily.



energy
saving
trust

endorsed
product

KEY FEATURES.

There is no wonder the Logic+ range is installed by thousands of installers across the country, with a range of key features built in as standard:

- Easy to see pressure gauge**
- Large backlit display with user friendly controls
- Low lift weight (starting from 29.2kg for combination models)
- Compact cupboard fit
- Preformed copper tails
- Pre-wired mains lead
- Wide range of flue options



**On combi and system models.

†Heating and hot water ErP A rating on combi models as shown. Heating ErP A rating on heat and system models.

LOGIC+ COMBI

C24 C30 C35.

Available in outputs of 24, 30 and 35 kW, the Logic+ Combi is designed to ensure a quick and hassle-free installation thanks to concealed connections, built-in automatic bypass and an integral filling loop.

A translucent condensate siphon also allows any debris to be spotted quickly and efficiently.

Siting the product is quick and simple too thanks to a telescopic flue, fast fix flue turret connections and zero compartment ventilation which allow the product to be installed neatly into a standard kitchen cupboard.

A backlit full size dot matrix screen provides symbols and plain English descriptions of heating and hot water functions, together with full fault information. Help text and service display provide further reassurance.

Complete with a 7 year parts and labour warranty* and recommended by the Energy Saving Trust, the Logic+ delivers total home comfort and customer peace of mind.

KEY FEATURES.

- Easy to see pressure gauge
- Large backlit display with user friendly controls
- Low lift weight (starting from 29.2kg)
- Low component count maximising reliability

RELIABLE

- Award winning range
- Energy Saving Trust endorsed
- 7 year parts and labour warranty*
- Built-in frost protection**
- Built-in filling loop
- Pre-heat function
- Service indication
- Latest generation Honeywell gas valve
- Simple diverter valve design with no dynamic seals

EASY TO INSTALL

- Compact cupboard fit
- Door to optional timers includes user instructions
- Fast fix flue options
- Wide range of additional flueing options
- Preformed copper tails
- Symbols and text display
- Pre-wired mains lead (2m) & spare fuses included
- Pre-piping kit
- Safety valve drain outlet pipe included
- Universal condensate connection
- Stand-off kit including piping
- Compatible with a range of additional controls inc. weather compensation and OpenTherm controls
- LPG conversion kit available for 30 kW boilers
- Four optional language user instructions***



7 YEAR WARRANTY*



COMPACT



FROST PROTECTION**



FLUE VARIANTS



LPG CONVERSION†



NOx CLASS 5



ErP COMPLIANT



QUIET MARK

LOGIC+ COMBI.

C24 C30 C35

*7 year warranty available until 31.12.2017. 5 year warranty as standard. Subject to terms and conditions. Parts and labour warranty available when registered within 30 days of installation. **Permanent live connection required. ***Available to download from www.idealboilers.com. †30 kW model only.



CONTROLS DISPLAY

- CH & DHW temperatures to radiators and out of taps
- Hot water preheat on/off
- Fault descriptions and corrective actions
- Full fault history and fault help
- Venting function
- Change pump speed
- Efficiency level
- Installer phone number displayed when service due
- Change service time
- Expanded display of sensor readings
- Pump/fan/valves data
- Max flow temperature limit
- Pump modulation
- Outside sensor slope



CLEARANCES & DIMENSIONS.

ALL DIMENSIONS IN MM

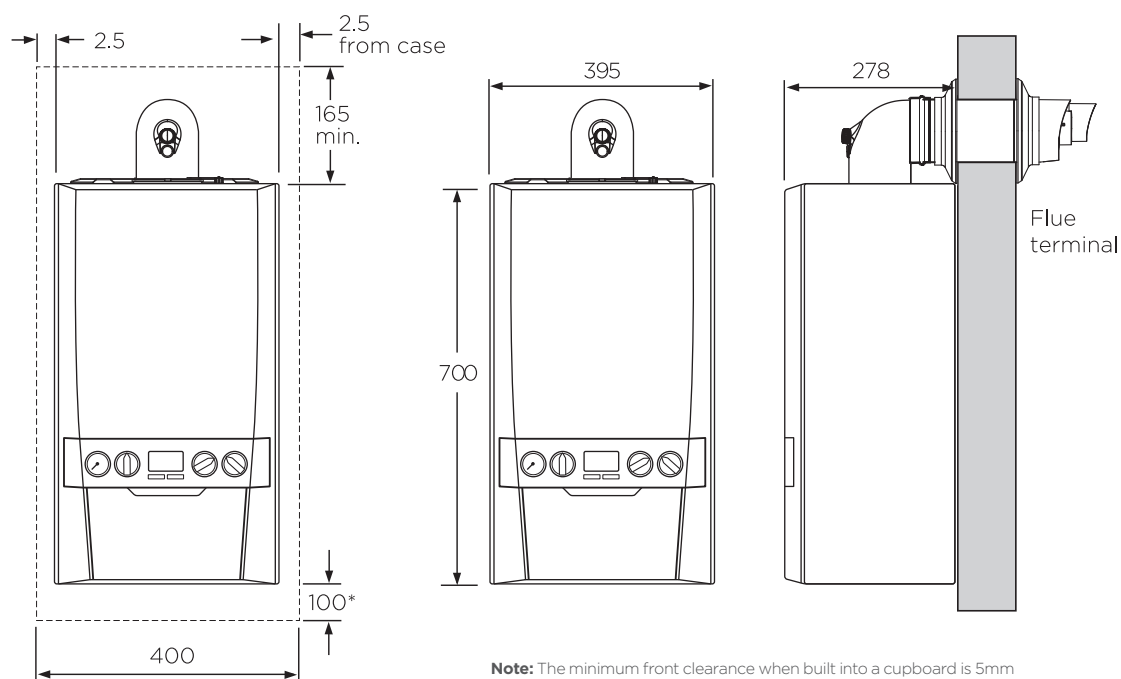

Note: The minimum front clearance when built into a cupboard is 5mm from the cupboard door but 450mm overall clearance with the cupboard door open is required for servicing.

*Bottom clearance after installation can be reduced to 5mm. However, 100mm is required for servicing.

LOGIC+ SYSTEM

S15 S18 S24 S30.

Endorsed by the Energy Saving Trust and available in a choice of four outputs – 15, 18, 24 and 30 kW, the Logic+ System is suitable for a wide variety of sealed domestic systems and features a lightweight compact cupboard fit design.* There are concealed connections at the base and no compartment ventilation is required, so the Logic+ System can be conveniently located out of sight in both new or replacement installations.

Product design and quality is paramount within the Logic+ System range; additional features such as a safety valve drain outlet pipe ensure total reliability and a hassle-free installation.

KEY FEATURES.

- Easy to see pressure gauge
- Large backlit display with user friendly controls
- Low lift weight (starting from 26.2kg)
- Low component count maximising reliability

RELIABLE

- Award winning range
- Energy Saving Trust endorsed
- 7 year parts and labour warranty[†]
- Built-in frost protection^{††}
- Service indication
- Latest generation Honeywell gas valve

EASY TO INSTALL

- Compact cupboard fit
- Wide range of flueing options
- Concealed pipe connections
- Preformed copper tails
- LPG Conversion kit available for 30 kW boilers
- Stand-off kit and pre-pipe options
- Safety valve drain outlet pipe included
- Pre-wired mains lead

LOGIC+ SYSTEM.

S15 S18 S24 S30



7 YEAR WARRANTY[†]



COMPACT



FROST PROTECTION^{††}



FLUE VARIANTS



LPG CONVERSION^{†††}



NOx CLASS 5



ErP COMPLIANT



QUIET MARK

*Please check kitchen cupboard size prior to installation.
[†]7 year warranty available until 31.12.2017. 5 year warranty as standard. Subject to terms and conditions.
^{††}Permanent live connection required. ^{†††}30 kW model only.



CONTROLS DISPLAY

- CH temperature to radiators
- Static fault codes
- Last 3 faults
- Venting function
- Change pump speed



CLEARANCES & DIMENSIONS.

ALL DIMENSIONS IN MM

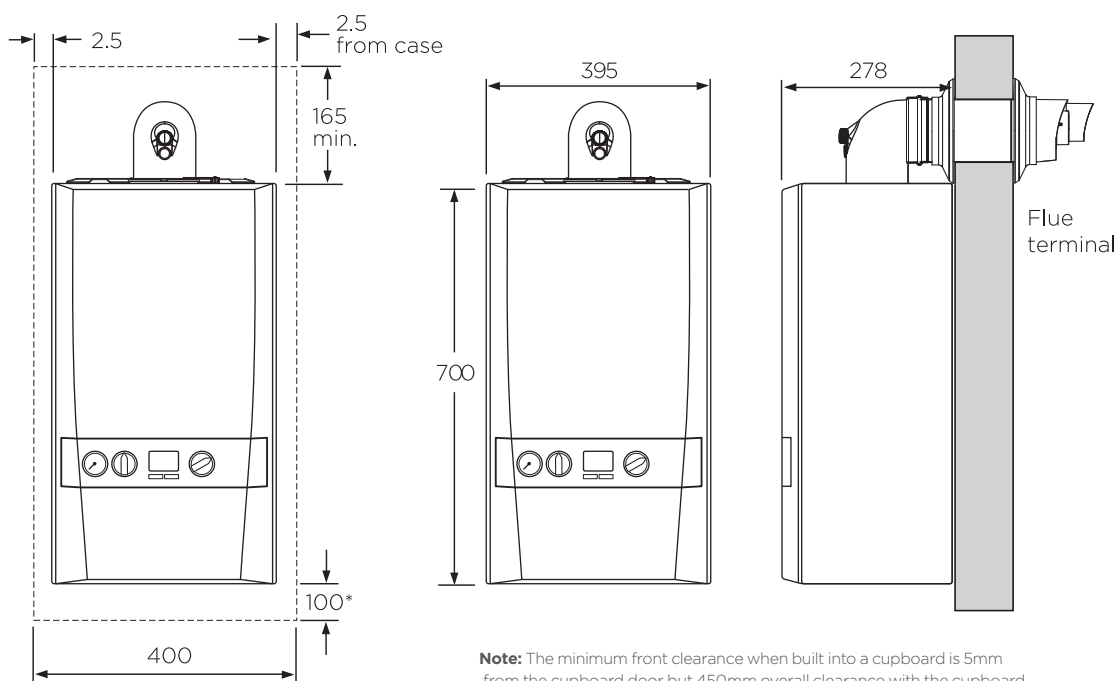

Note: The minimum front clearance when built into a cupboard is 5mm from the cupboard door but 450mm overall clearance with the cupboard door open is required for servicing.

*Bottom clearance after installation can be reduced to 5mm. However, 100mm is required for servicing.

LOGIC+ HEAT

H12 H15 H18 H24 H30.

Incorporating the latest in heating design and technology, the Logic+ Heat is an outstanding heat only solution for both new build or replacement installations alike.

Available in a choice of five outputs - 12, 15, 18, 24 and 30 kW, the Logic+ Heat will deliver total home comfort for a wide range of domestic properties.

Suitable for open vent and sealed systems, the Logic+ Heat boiler is straightforward to site and install. No compartment ventilation, compact fit and a lightweight design mean the boiler can be neatly installed out of sight in a kitchen cupboard.*

Installers have the further choice of neat direct rear flue options as required, helping to further speed up the installation in retro fit situations.

KEY FEATURES.

- Large backlit display with user friendly controls
- Low lift weight (22.7kg)
- Low component count maximising reliability

RELIABLE

- Award winning range
- Energy Saving Trust endorsed
- 7 year parts and labour warranty†
- Boiler frost protection**
- Water flow sensor
- Latest generation Honeywell gas valve

EASY TO INSTALL

- Compact cupboard fit
- Direct 80mm diameter rear flue option
- Wide range of flueing options
- Top system connections
- 75mm deep translucent condensate siphon
- Stand-off kit
- Terminal wall plate kit
- Security bracket kit
- Low minimum head requirement
- LPG conversion kit available for 30 kW boilers
- Fully modulating operation down to 4.8 kW***
- Weather compensation kit option



7 YEAR WARRANTY†



COMPACT



FROST PROTECTION**



FLUE VARIANTS



LPG CONVERSION****



NOx CLASS 5



DIRECT REAR FLUE



ErP COMPLIANT



QUIET MARK

LOGIC+ HEAT.

H12 H15 H18 H24 H30

*Please check kitchen cupboard prior to installation.
 †7 year warranty available until 31.12.2017. 5 year warranty as standard. Subject to terms and conditions. Parts and labour warranty available when registered within 30 days of installation.
 Permanent live connection required. *30 kW only - 6.1 kW). ****30 kW model only.



CONTROLS DISPLAY

- CH temperature to radiators
- Static fault codes
- Last 3 faults
- Venting function
- Change pump speed

CLEARANCES & DIMENSIONS.

ALL DIMENSIONS IN MM

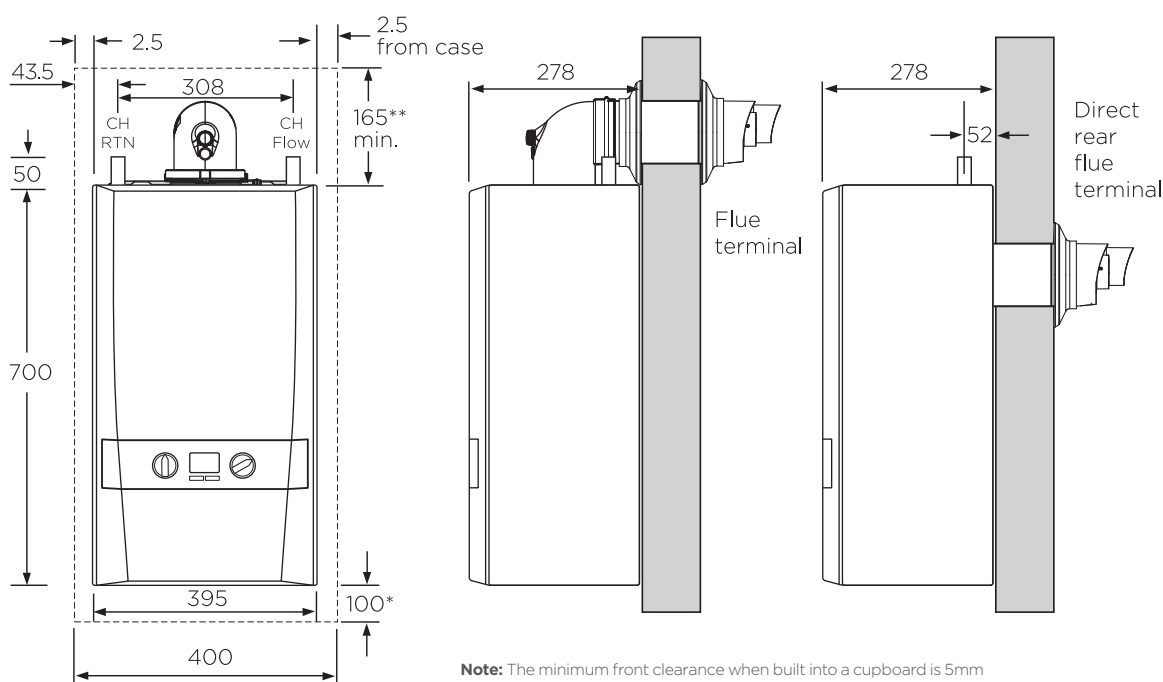

Note: The minimum front clearance when built into a cupboard is 5mm from the cupboard door but 450mm overall clearance with the cupboard door open is required for servicing.

*Bottom clearance after installation can be reduced to 5mm. However, 100mm is required for servicing.
 **Rear flue option - top clearance 100mm.

TECHNICAL SPECIFICATION.

		LOGIC+ COMBI		
BOILER MODEL		C24	C30	C35
PRODUCT CODE		215439	215440	215441
SIZE	Height (mm)	700	700	700
	Width (mm)	395	395	395
	Depth (mm)	278	278	278
	Weight (packed) kg	34.0	34.1	34.2
	Maximum installation weight kg	29.2	29.3	29.4
PERFORMANCE	CH output (kW) Min/Max mean 70°C	4.8 - 24.2	6.1 - 24.2	7.1 - 24.2
	CH output (kW) Min/Max mean 40°C	5.1 - 25.6	6.4 - 25.6	7.5 - 25.6
	DHW output (kW) Max	24.2	30.3	35.3
	DHW flow rate l/min. 35°C rise	9.9	12.4	14.5
	SEDBUK (2005) %	91.1	91.1	91.1
	SEDBUK (2009/2012) %	89.6	89.6	89.6
	NOx Classification	CLASS 5	CLASS 5	CLASS 5
	Optional LPG kit	No	Yes	No
CONSTRUCTION	Heat exchanger material	Cast Aluminium - Silicon Alloy		
	Burner type	Downward firing pre-mix		
	Fully modulating	Yes	Yes	Yes
	DHW plate heat exchanger	Yes	Yes	Yes
	Integrated hydrobloc	Yes	Yes	Yes
INSTALLATION	Suitable for sealed systems	Yes	Yes	Yes
	Suitable for open-vent systems	No	No	No
	Filling loop	Yes	Yes	Yes
	Pre-wired mains lead	Yes	Yes	Yes
	Flow regulator	Yes	Yes	Yes
	In-built system bypass	Yes	Yes	Yes
	In-built condensate trap/siphon	Yes	Yes	Yes
	In-built boiler frost protection	Yes	Yes	Yes
	Zero compartment ventilation	Yes	Yes	Yes
CLEARANCES	Top (min. mm) from top of boiler	165	165	165
	Side (mm)	2.5	2.5	2.5
	Bottom (mm)	100*	100*	100*
	Front (mm)	450*	450*	450*
USER INTERFACE	User display	Symbols and text		
	User interface	3 dials, 2 buttons		
	Diagnostics	Plain English text		
	User adjustable	Manual heating & hot water controls		
	'Eco' setting on CH	Yes	Yes	Yes
	In-built programmer	Optional	Optional	Optional
PIPES	Pre-piping kit	Optional	Optional	Optional
	Stand-off kit	Optional	Optional	Optional
	Stand-off kit inc. pipes	Optional	Optional	Optional
FLUES	Max horizontal	9m	8m	6m
	Max vertical	7.5m	7.5m	7.5m
	Powered vertical**	22m	22m	22m
	Direct rear flue kit (55/80)	No	No	No
CONNECTIONS**	Gas supply connection	15mm copper compression		
	CH flow connection	22mm copper compression		
	CH return connection	22mm copper compression		
	Inlet connection - DHW	15mm copper compression		
	Outlet connection - DHW	15mm copper compression		
	Condensate drain	21.5mm		
ErP EFFICIENCIES	Condensing boiler	Yes	Yes	Yes
	Seasonal space heating efficiency class	A	A	A
	Rated heat output kW	24	24	24
	Seasonal space heating energy efficiency η_s %	94	94	94
	Sound power level, indoors LWA dB	48	46	44
	Water heating energy efficiency class	A	A	A

*Can be reduced to 5mm. 450mm required for servicing (front), 100mm (bottom). **Refer to Powered Vertical instructions for details.

†Also available: High Level Flue Outlet Kit/Direct Rear Flue Kit (55/80). **For outputs exceeding 18 kW, 28mm primary pipework may be required.

+ VOGUE GEN2

SHOWCASING UNIQUE BOILER INNOVATION, THE VOGUE GEN2 FROM IDEAL BOILERS UTILISES MODERN TECHNOLOGY, TEAMED WITH PREMIUM PARTS AND COMPONENTS TO BRING YOU THE NEXT STEP IN DOMESTIC HEATING INTELLIGENCE.

The complete design, from component specification, manufacture and build, through to consumer use is engineered with quality in mind. All models in the Vogue GEN2 range deliver premium performance, reliability and are supported by a premium aftersales support service and an 8 year warranty as standard, which can be increased to 10 years when fitted with an Ideal System Filter.



KEY FEATURES.

The Vogue GEN2 range comes complete with premium components and up to a 10 year warranty* for complete peace of mind. Vogue GEN2 is the ideal solution for customers looking for a premium product for their home.

- Backlit 3.5" LCD full colour display
- Built using premium components
- Low lift weight from 30.7kg (up to 2.6kg lighter than previous models)
- Multi-function buttons for simplified end user operation
- Easy to read pressure gauge
- Uniform control opening across all Ideal products
- Quick installation – single piece unit



*10 year warranty when installed with an Ideal System Filter. 8 years parts & labour warranty as standard. Terms and conditions apply.

†Heating and hot water ErP A rating on combi models as shown. Heating ErP A rating on system models.

VOGUE GEN2.

COMBI C26 C32 C40 SYSTEM S15 S18 S26 S32

VOGUE GEN2

COMBI C26 C32 C40 SYSTEM S15 S18 S26 S32.

Every model in the Vogue GEN2 range comes complete with an 8 year warranty as standard, which can be increased to 10 years parts and labour warranty when installed with an Ideal System Filter. When choosing Vogue GEN2, installers and homeowners can rest assured that they will be receiving ultimate peace of mind.

Unrivalled levels of reliability are achieved through integrated product design - only high specification components and interface are used, and all our suppliers have market leading technical competence and quality assured processes.

KEY FEATURES.

- Backlit 3.5" LCD full colour display
- Built using premium components
- Low lift weight from 30.7kg (up to 2.6kg lighter than previous models)
- Multi-function buttons for simplified end user operation
- Easy to read pressure gauge
- Uniform control opening across all Ideal products

RELIABLE

- 10 year warranty when installed with an Ideal System Filter*
- 24V gas valve replacing 230V providing reliability improvement
- Hydrobloc incorporating a 24V stepper for improved reliability

EASY TO INSTALL

- Quick installation - single piece unit
- Long maximum flue lengths with easy access sampling points
- Pre-wired mains lead (2m) simplifying installation

PRODUCT INTELLIGENCE

- Cool door technology
- Up to 7:1 modulation
- Large 10 litre expansion vessel
- Service display and installer phone number input
- Rotary control for easier user operation

PREMIUM COMPONENTS

- Stylish aesthetics with full size door complete with damped opening
- Stainless steel heat exchanger
- Low energy modulating UPM3 Grundfos pump
- Control box with push-in cable clamps and upgraded display capability



10 YEAR WARRANTY WHEN INSTALLED WITH AN IDEAL SYSTEM FILTER*



QUICK INSTALLATION - SINGLE PIECE UNIT



SIMPLE TO INSTALL & SERVICE



LCD COLOUR DISPLAY



LOW LIFT WEIGHT



COMPACT



FROST PROTECTION



FLUE VARIANTS



NOx CLASS 5



LPG CONVERSION



ErP COMPLIANT†

*10 year warranty when installed with an Ideal System Filter. 8 years parts & labour warranty as standard. Terms and conditions apply.
†Heating and hot water ErP A rating on combi models as shown. Heating ErP A rating on system models.

IDEAL SYSTEM FILTER



10 YEAR WARRANTY ON VOGUE GEN2 WHEN INSTALLED WITH AN IDEAL SYSTEM FILTER. SEE PAGE 23 FOR FULL FILTER DETAILS.

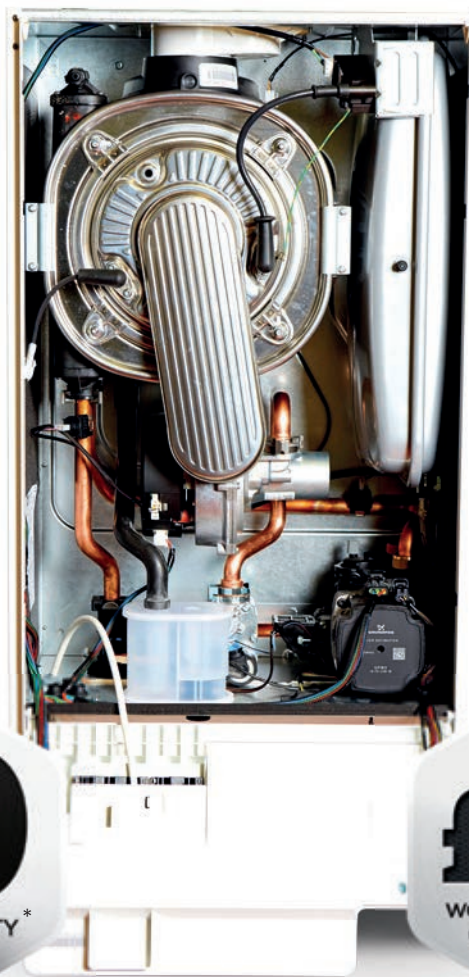

10
YEAR WARRANTY*

UP TO
£55
WORTH OF INSTALLER*
CONNECT POINTS

CLEARANCES & DIMENSIONS.

ALL DIMENSIONS IN MM

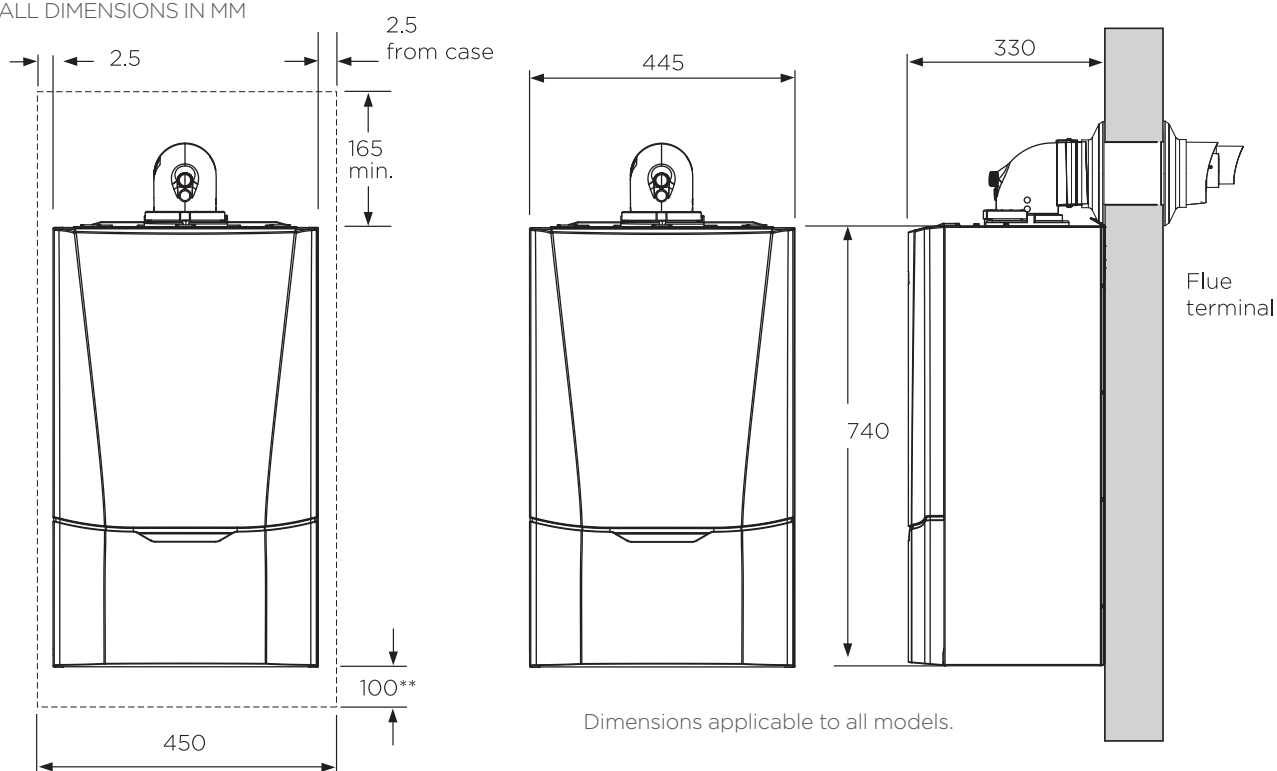

*10 year warranty when installed with an Ideal System Filter. 8 years parts & labour warranty as standard. Terms and conditions apply.
**Bottom clearance after installation can be reduced to 5mm. However, 100mm is required for servicing.

TECHNICAL SPECIFICATION.

		VOGUE GEN2 COMBI		
BOILER MODEL		C26	C32	C40
PRODUCT CODE		216358	216359	216360
SIZE	Height (mm)	740	740	740
	Width (mm)	445	445	445
	Depth (mm)	330	330	330
	Packaged weight (kg)	37.6	38.9	40.9
	Installation weight (kg)	32.4	33.8	35.4
PERFORMANCE	CH output (kW) Min/Max mean 70°C	3.7-18.0	4.6-26.0	5.7-32.0
	CH output (kW) Min/Max mean 40°C	4.0-19.3	4.9-27.9	6.1-34.3
	DHW output (kW) Max	26	32	40
	DHW flow rate l/min. 35°C rise	10.6	13.1	16.4
	SEDBUK (2005) %	91	91.1	91
	SEDBUK (2009/2012) %	89.1	89.2	89.1
	NOx Classification	5	5	5
	Optional LPG kit	Yes	Yes	Yes
CONSTRUCTION	Heat exchanger material	Stainless steel	Stainless steel	Stainless steel
	Burner type	Pre-mix with cool burner door		
	Fully modulating output	7:1	7:1	7:1
	DHW plate heat exchanger	Yes	Yes	Yes
	Integrated hydrobloc	Yes	Yes	Yes
INSTALLATION	Suitable for sealed systems	Yes	Yes	Yes
	Suitable for open-vent systems	No	No	No
	Filling loop	Yes	Yes	Yes
	Pre-wired mains lead	Yes	Yes	Yes
	In-built system bypass	Yes	Yes	Yes
	In-built condensate trap/siphon	Yes	Yes	Yes
	In-built boiler frost protection	Yes	Yes	Yes
	Safety valve drain outlet pipe	Yes	Yes	Yes
	Zero compartment ventilation	Yes	Yes	Yes
CLEARANCES	Top (min. mm) (from top of boiler)	165	165	165
	Side (mm)	2.5	2.5	2.5
	Bottom (mm)	100*	100*	100*
	Front (mm)	450*	450*	450*
USER INTERFACE	User display	Large full colour backlit LCD with text & symbols		
	User interface	Text display & multi-function buttons		
	Diagnostics	Plain English text		
	User adjustable	Manual heating & hot water controls		
	DHW preheat	Yes	Yes	Yes
	Pressure gauge	Analogue in control panel		
	In-built programmer	Optional (Mech. & electronic)		
PIPES	Stand-off kit	Yes	Yes	Yes
	Stand-off kit inc. pipes.	Yes	Yes	Yes
FLUES	Max horizontal	10	8	8
	Max vertical	10	10	10
CONNECTIONS**	Gas supply connection	22mm copper compression		
	CH flow connection	22mm copper compression		
	CH return connection	22mm copper compression		
	Inlet connection - DHW	15mm copper compression		
	Outlet connection - DHW	15mm copper compression		
	Condensate drain	21.5mm Universal		
ErP EFFICIENCIES	Condensing boiler	Yes	Yes	Yes
	Seasonal space heating efficiency class	A	A	A
	Rated heat output kW	18	26	32
	Seasonal space heating energy efficiency η_s %	93	93	93
	Sound power level, indoors LWA dB	47	50	49
	Water heating energy efficiency class	A	A	A

*Can be reduced to 5mm, 450mm required for servicing (front), 100mm (bottom).

**For outputs exceeding 18kW, 28mm primary pipework may be required.

VOGUE GEN2 SYSTEM			
S15	S18	S26	S32
216354	216355	216356	216357
740	740	740	740
445	445	445	445
330	330	330	330
35.5	36.3	37.7	39.7
30.7	31.5	32.9	34.3
3.0-15.0	3.6-18.0	5.2-26.0	6.4-32.0
3.2-16.2	3.9-19.3	5.6-27.9	6.8-34.3
N/A	N/A	N/A	N/A
N/A	N/A	N/A	N/A
91	91.1	91.1	91.1
88.9	89.3	89.3	89.3
5	5	5	5
Yes	Yes	Yes	Yes
Stainless steel	Stainless steel	Stainless steel	Stainless steel
	Pre-mix with cool burner door		
5:1	5:1	5:1	5:1
N/A	N/A	N/A	N/A
N/A	N/A	N/A	N/A
Yes	Yes	Yes	Yes
No	No	No	No
No	No	No	No
Yes	Yes	Yes	Yes
Yes	Yes	Yes	Yes
Yes	Yes	Yes	Yes
Yes	Yes	Yes	Yes
Yes	Yes	Yes	Yes
Yes	Yes	Yes	Yes
165	165	165	165
2.5	2.5	2.5	2.5
100*	100*	100*	100*
450*	450*	450*	450*
Large full colour backlit LCD with text & symbols			
Text display & multi-function buttons			
Plain English text			
Manual heating control			
N/A	N/A	N/A	N/A
Analogue in control panel			
No	No	No	No
Yes	Yes	Yes	Yes
Yes	Yes	Yes	Yes
10	10	10	8
10	10	10	10
22mm copper compression			
22mm copper compression			
22mm copper compression			
N/A			
N/A			
21.5mm Universal			
Yes	Yes	Yes	Yes
A	A	A	A
15	18	26	32
92	93	93	93
50	52	52	50
N/A	N/A	N/A	N/A



CONTROLS & ACCESSORIES

WE BELIEVE THAT CHOOSING THE RIGHT CONTROL TO MEET THE NEEDS OF YOUR CUSTOMER IS AS IMPORTANT AS CHOOSING THE RIGHT BOILER; THAT'S WHY THE LOGIC+ AND VOGUE GEN2 BOILERS ARE FULLY COMPATIBLE WITH A RANGE OF THERMOSTATS AND TIMERS FOR THE ULTIMATE IN HOME COMFORT.

QUALIFIES FOR
INSTALLER CONNECT
POINTS



TOUCH.

Ideal's new electronic programmable room thermostat featuring simple user interface, 7 day timed control of central heating, wireless connection and built in frost protection.

- Part No. 214216 Logic+ Combi and Vogue GEN2 Combi only

ErP: Class 5, 3% additional efficiency.

MECHANICAL TIMER.

Simple heating control through a plug-in analogue timer. 24 hour tappet operation with off/timed/continuous periods.

- Part No. 215390 Logic+ Combi and Vogue GEN2 Combi only

ErP: Class 0, no additional efficiency.



RF ELECTRONIC PROGRAMMABLE THERMOSTAT.

Wireless Radio Frequency (RF) digital timer and room thermostat providing heating control. 7 day, plain text operating and diagnostics display. Automatic summer/winter time update.

- Part No. 216131 Logic+ Combi and Vogue GEN2 Combi only

ErP: Class 5, 3% additional efficiency.



WEATHER COMPENSATION OUTDOOR SENSOR.

Ideal Boiler ranges provide weather compensation when fitted with an outdoor sensor (which is available as an optional accessory). Weather compensation works by measuring the temperature outside the home and adjusting the temperature (or flow) of the radiators inside. If the weather is particularly cold outside, the outdoor sensor will communicate with the boiler intelligently to increase the radiator temperature. This process also works in reverse, as the outdoor temperature increases, the flow to the radiators will decrease. This process allows the system to operate more efficiently by only heating to the minimum temperature necessary and also preventing spikes in heating activity.

- Part No. 216119 Logic+, Vogue GEN2 Combi & System

ErP: Class 2, 2% additional efficiency.



IDEAL SYSTEM FILTER. (Part No. 217528)

- 10 year warranty
- 10 year warranty on Vogue GEN2 when installed with an Ideal System Filter
- Qualifies for £5 of Installer Connect points
- Compact design - simple to locate in restricted spaces
- Easy to install - fits on horizontal or vertical pipework in both flow directions. The filter can operate at angles of 45°
- Fast and easy to clean without dismantling the unit
- Double action, removes magnetic and non-magnetic contaminants from system water
- Will not block or restrict flow
- Forged brass construction (no hidden porosity)
- Double radial seals and multiple orientation capability
- Powerful neodymium magnet assembly with threaded magnet cap
- Available in 22mm
- Easy to dose heading system via filter with inhibitor



£5

WORTH OF INSTALLER
CONNECT POINTS



LPG CONVERSION KITS

WITH KITS AVAILABLE FOR NATURAL GAS TO LPG, THESE QUICK TO INSTALL ACCESSORIES PROVIDE A SIMPLE AND PRAGMATIC SOLUTION WITHOUT THE NEED FOR PRODUCTS TO BE ADJUSTED.

EACH KIT CONTAINS SPECIFIC COMPONENTS FOR EACH REQUIRED BOILER TYPE.

LOGIC+ NATURAL GAS TO LPG KIT CONTENTS.

EACH KIT COMPRISES:

- Gas valve (preset operation)
- Burner injector
- Data plate labels
- Instructions

Use of a preset gas valve ensures that set up is simple and easy, reducing commissioning time.

Two data plate labels are provided in the kits inclusive of a new data plate providing LPG details, and a label to retain boiler serial number identity.

KEY FEATURES

- Available for all Logic+ range (Combi, Heat & System)
- Suitable for most property sizes
- Fast & simple conversion with pre-set gas valve for no product adjustment

PRODUCTS APPLICABLE

- Logic+ Combi C30 kW
- Logic+ Heat H30 kW
- Logic+ System S30 kW



VOGUE GEN2 NATURAL GAS TO LPG KIT CONTENTS.

EACH KIT COMPRISES:

- Burner injector
- Data plate labels
- Instructions

Two data plate labels are provided in the kits inclusive of a new data plate providing LPG details, and a label to retain boiler serial number identity.

KEY FEATURES

- Available for all Vogue GEN2 Combi and System models
- Fast & simple conversion using boiler controls and injector

PRODUCTS APPLICABLE

- Vogue GEN2 Combi C26, C32, C40 kW
- Vogue GEN2 System S15, S18, S26, S32 kW

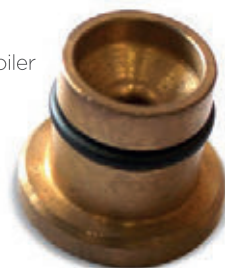

LPG HEAT OUTPUTS.

BOILER MODEL	LOGIC+			VOGUE GEN2 COMBI			VOGUE GEN2 SYSTEM			
	COMBI C30	HEAT H30	SYSTEM S30	C26	C32	C40	S15	S18	S26	S32
Min. output (kW)	8.0	8.0	8.0	4.4	5.4	6.7	3.8	4.4	5.2	8.0
Max. output (kW)	24.2	30.3	30.3	18.0	26.0	32.0	15.0	18.0	26.0	32.0
Max. DHW output (kW)	30.3	N/A	N/A	26.0	32.0	40.0	N/A	N/A	N/A	N/A

PRODUCT CODE

NG - LPG CONVERSION KITS

215740	Logic+ Combi C30
215744	Logic+ Heat H30
215746	Logic+ System S30
217081	Vogue GEN2 Combi C26
217082	Vogue GEN2 Combi C32
217083	Vogue GEN2 Combi C40
217084	Vogue GEN2 System S15
217085	Vogue GEN2 System S18
217086	Vogue GEN2 System S26
217087	Vogue GEN2 System S32

+ HIGH EFFICIENCY CYLINDERS

IF YOU'RE INSTALLING A HEAT ONLY OR SYSTEM BOILER FROM THE IDEAL LOGIC+ OR VOGUE GEN2 RANGE, THEN CONSIDER THE IDEAL UNVENTED CYLINDER RANGE - THE PERFECT SOLUTION FOR NEW OR REPLACEMENT INSTALLATIONS.



2
YEAR PARTS
WARRANTY

25
YEAR VESSEL
WARRANTY

UNVENTED STAINLESS CYLINDERS.

IDEAL UNVENTED CYLINDER 90 120 150 180 210 250 300 400.

The Ideal Unvented Cylinder is a range of stainless steel, indirect cylinders which are manufactured to the highest standards. We have 8 models in the range, all with a 2 year

parts and labour warranty, so you can be sure the Ideal Unvented Cylinder allies the twin demands of excellent product quality with outstanding value.

KEY FEATURES.

- 2 year parts and labour, and 25 year vessel warranty
- Duplex stainless steel construction to offer excellent resistance to corrosion
- New flat top and base providing up to 20% more HCFC insulation
- Improved ErP ratings of A for 90L and B for 210L
- Aligned tapping positions for ease of installation
- Colour matched components for improved aesthetics
- Wider base for additional stability
- Rubber connection labels and improved caps with foam retention
- Corrugated heat transfer coil to give 20% faster recovery than plain tube
- Manufactured in accordance with BS EN 12897
- Complete with all quality fittings according to model
- Lightweight for ease of installation
- Low standing heat loss

HOME SET UP.

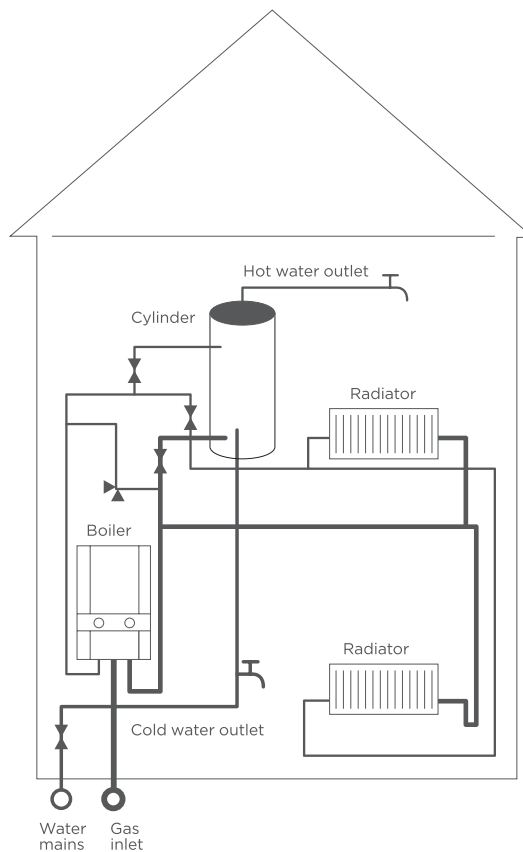

STANDARD APPLIANCE.

- Hot water draw of 22mm compression
- Temperature and pressure relief valve 90°C/6 bar
- Hot water secondary return 22mm (not fitted to cylinders below 210 litres)
- Immersion heater 1 3/4" BSP 3 kW
- Cold supply 22mm compression
- Dual control/overheat thermostat pocket
- Boiler control sensor pocket (spare)
- Primary flow 22mm compression (28mm tails for 400 litre model only)
- Primary return 22mm compression (28mm tails for 400 litre model only)



STANDARD COMPONENTS SUPPLIED.

- Combination inlet group incorporating pressure reducing valve, strainer, check valve, balanced cold take-off point, expansion relief valve and expansion vessel connection points
- Potable expansion vessel complete with flexible hose and integrated wall bracket
- Tundish
- Dual control thermostat and combined overheat thermostat
- Two port 22mm zone valve for primary circuit
- Wiring junction box for primary system



TECHNICAL SPECIFICATION.

CYLINDER MODEL		IDEAL UNVENTED CYLINDER							
		90	120	150	180	210	250	300	400
SIZE	Height (mm)	764	931	1118	1306	1494	1744	1990	2030
	Diameter (mm)	550	550	550	550	550	550	550	630
	Weight (empty) (kg)	20	23	26	30	33	38	43	55
	Weight (full) (kg)	111	142	174	208	241	286	330	455
	Capacity (litres)	91	119	148	178	208	248	287	393
PERFORMANCE	Pressure regulator (bar)	3	3	3	3	3	3	3	3
	Expansion vessel size (litres)	12	12	18	18	24	24	35	2 x 24
	Rating of primary coil (kW)	16.5	18.0	18.5	19.0	20.5	21.5	25.0	30.5
	Heat up time from 15°C to 60°C (min)	17	21	25	30	32	36	38	41
	Efficiency class	A	B	B	B	B	C	C	C
	Heat loss (watts)	32	39	47	55	62	74	86	87

FLUE SITING.

There are a substantial number of fluing options available for Ideal boiler ranges, giving excellent siting flexibility for almost all applications.

The range of options include standard and telescopic flue as well as roof flue and powered vertical flue options.

To ensure siting issues are kept to a minimum, High Level Flue Outlet kit options and Flue Deflector kits are available.

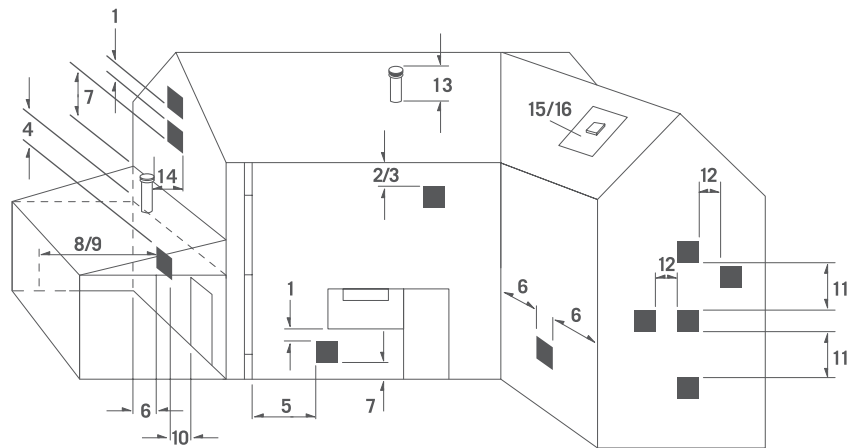

MINIMUM DIMENSIONS OF FLUE TERMINAL POSITIONS.

FLUE TERMINAL POSITION	MIN. SPACING
1. Directly below, above or alongside an opening window, air vent or other ventilation opening.	300mm
2. Below guttering, drain pipes or soil pipes BS5440-1	25mm* 75mm
3. Below eaves. BS5440-1	25mm* 200mm
4. Below balconies or car port roof. BS5440-1	25mm* 200mm
5. From vertical drain pipes or soil pipes. BS5440-1	25mm* 150mm
6. From an internal or external corner or to a boundary alongside the terminal. BS5440-1 2008	25mm* 300mm
7. Above adjacent ground, roof or balcony level.	300mm
8. From a surface or boundary facing a terminal.	600mm
9. From a terminal facing a terminal.	1200mm
10. From an opening in a car port (e.g. door or window) into dwelling.	1200mm
11. Vertically from a terminal on the same wall.	1500mm
12. Horizontally from a terminal on the wall.	300mm

VERTICAL FLUES

13. Above the roof pitch with roof slope of all angles.	300mm
Above flat roof.	300mm
14. From a single wall face.	300mm
From corner walls.	300mm
15. Below Velux window.	2000mm
16. Above or side of Velux window.	600mm

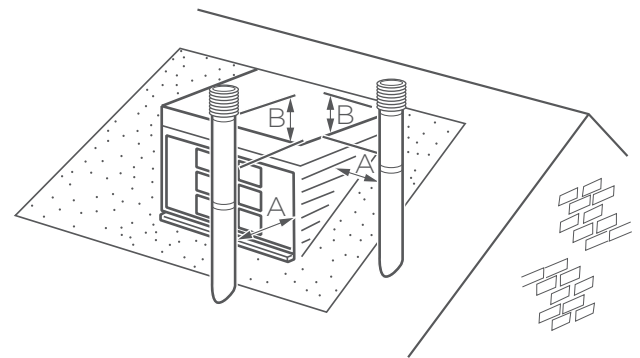
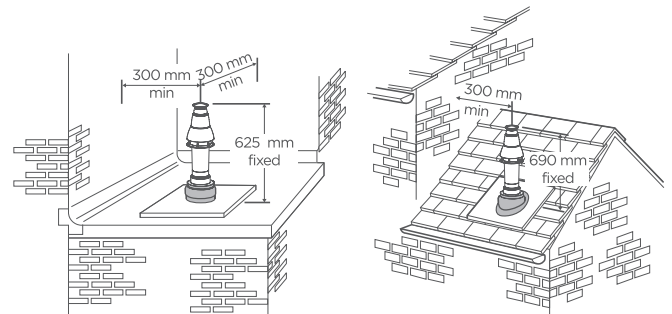

If chimney penetrates dotted area such that A is less than 300mm, B shall not be less than 300mm.

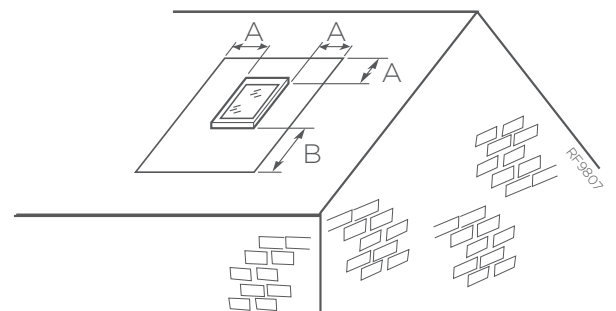

A = 600mm
B = 2000mm

The flue terminal shall not penetrate the shaded area of the roof.

*Only one reduction down to 25mm is allowable per installation otherwise BS5440-1 dimensions must be followed.

LOGIC+ & VOGUE GEN2 FLUE KITS.

- Part No. 208171 Horizontal flue terminal (0.6m long)
- Part No. 217442 Horizontal flue terminal (1m long)
- Part No. 208169 Telescopic B pack flue (0.6m long)
- Part No. 208174 Telescopic horizontal flue terminal (1m long)
- Part No. 208290 Raised horizontal flue kit
- Part No. 203129 Flue extension 1m (pack D)
- Part No. 203130 Flue elbow 90 deg kit (60/100)
- Part No. 203131 Flue elbow 45 deg kit (60/100) (pair)
- Part No. 208178 High level flue outlet kit
- Part No. 203228 Flue extension kit 60 dia (1m) for high level flue outlet kit
- Part No. 203229 High level 90 deg elbow
- Part No. 203230 High level 45 deg elbow (pair)
- Part No. 152258 Weather collar universal 100 dia (fits slate & tiles)
- Part No. 152259 Weather collar flat roof 100 dia
- Part No. 208176 Flue deflector kit 60 dia (clips on end of flue & angles plumbing away)
- Part No. 205990 Rear flue outlet kit 55/80 (Logic+ heat only)
- Part No. 205989 High level outlet kit 55/80 (Logic+ heat only, rear flue only)
- Part No. 208177 Balcony flue outlet kit
- Part No. 211037 Flue extension 0.5m kit (Pack D)
- Part No. 211038 Flue extension 2m kit (Pack D)
- Part No. 211039 Roof flue kit (with vertical connector)
- Part No. 211302 Soffit kit 60/100
- Part No. 205247 Flue bracket kit
- Part No. 208175 Flue vertical connector
- Part No. 205024 Concentric flue screw retaining kit
- Part No. 155988 Flue finishing kit
- Part No. 203134 Flue powered vertical terminal 100 dia (Logic+ only)
- Part No. 203136 Vertical powered flue kit (Logic+ only)
- Part No. 203142 Flue extension pipe 80 dia (pair) twin/vertical (Logic+ only)

LOGIC+ ACCESSORIES.

- Part No. 211103 Stand off kit
- Part No. 211101 Stand off kit (including upward piping; combi)
- Part No. 211330 Stand off kit with pipes Logic System
- Part No. 206153 Stand off kit Logic Heat
- Part No. 211328 Terminal wall plate RS kit combi & system
- Part No. 206164 Terminal wall plate kit RS replacement (heat)
- Part No. 205419 Kit - DHW expansion vessel
- Part No. 211041 Pre-piping kit (combi)
- Part No. 211331 Pre-piping kit (system)
- Part No. 205217 Security bracket kit
- Part No. 159991 Condensate pump kit
- Part No. 204565 Secondary pressure relief valve kit

VOGUE GEN2 ACCESSORIES.

- Part No. 208442 Stand off kit Vogue
- Part No. 217088 Stand off kit (including piping) Vogue GEN2 Combi
- Part No. 217089 Stand off kit (including piping) Vogue GEN2 System
- Part No. 205419 Kit - DHW expansion vessel
- Part No. 159991 Condensate pump kit
- Part No. 204565 Secondary pressure relief valve kit
- Part No. 205217 Security bracket kit



+ GREAT BOILERS FROM GREAT BRITAIN.



Ideal Boilers
PO Box 103
National Avenue
Kingston upon Hull
East Yorkshire
HU5 4JN

T 01482 492251
enquiries@idealboilers.com

WWW.IDEALBOILERS.COM



The information in this brochure was correct at the time of going to print. Ideal Boilers reserve the right to make any modifications to product specifications or any other details, without prior notification. For further clarification, please enquire in writing to the head office address opposite.

